

**Digital Cam Switch Unit**

# CamCon DC33



## **Digitronic Automationsanlagen GmbH**

Steinbeisstraße 3 · D - 72636 Frickenhausen · Tel. (+49)7022/40590-0 · Fax -10  
Auf der Langwies 1 · D - 65510 Hünstetten-Wallbach · Tel.(+49)6126/9453-0 · Fax -42  
Internet: <http://www.digitronic.com> · E-Mail: [mail@digitronic.com](mailto:mail@digitronic.com)

### For your attention

This instruction manual relates to the CamCon DC33 from November 1996. The company Digitronic Automationsanlagen GmbH reserves the right to make changes which present an improvement of the quality or functionality of the device without prior notice. The instruction manual was created with great care, although it may not be error-proof. We would be grateful for any communication relating to any errors you may have found.

### UP-date

You can also access this instruction manual on the Internet at <http://www.digitronic.com> in the latest version as PDF file.

### Qualified personnel

This device may only be started and operated by qualified staff. By qualified we mean personnel who are entitled to handle, to earth and to label devices, systems and power circuits in accordance with the technology safety standards.

### Liability

(1) The supplier is liable for damages caused by himself or by the owner of the rights up to the sum of the sales price. He is not liable for loss of profits, forfeited savings, intermediate and successive damages.

(2) The above mentioned limits to liability do not apply to insurance of named characteristics and damages which were caused deliberately or through negligence.

### Protection

The CamCon DC33 and this instruction manual are protected by copyright. All rights are reserved. Neither the CamCon DC33, nor this document may be copied as a whole, photocopied, reproduced, translated or transferred to electronic media of any kind or into machine readable format without prior written permission by the company Digitronic Automationsanlagen GmbH.

**Note:** We have examined the devices of the CamCon series for year 2000 compatibility and have not found any adverse effects on any functions.

**Note:** CamCon is a registered trademark of the company Firma Digitronic Automationsanlagen GmbH.

**Note:** The devices of the CamCon series comply with the standards for electromagnetic compatibility: EN 55011, EN 55022, EN 55024 Part 2, EN 50082 Part 2, ENV 50140, VDE 0843 Part 2, VDE 0843 Part 4, VDE 0871, VDE 0875 Part 3 ("N"), VDE 0875 Part 11, VDE 0877 Part 2, IEC 801 Part 3, IEC 801 Part 2, IEC 801 Part 4, IEC 801 Part 5.



(c) Copyright 1992 - 2002 / File: DC33\_E.DOC

Digitronic Automationsanlagen GmbH  
Auf der Langwies 1  
D-65510 Hünstetten - Wallbach  
Tel. (+49)6126/9453-0 Fax. (+49)6126/9453-42  
Internet: <http://www.digitronic.com>  
E-Mail: [mail@digitronic.com](mailto:mail@digitronic.com)

**TABLE OF CONTENTS**

1. Introduction.....	4
2. Principle of function.....	5
2.1. Delay time compensation.....	6
2.1.1. Calculating the delay time .....	8
2.1.1.1. Calculating the delay time through relocations that have already occurred.....	8
2.1.1.2. Calculating the delay time through the difference of measured values.....	8
3. Installation .....	9
3.1. Dimensions .....	9
4. Electrical connections .....	10
4.1. Pin allocation CamCon with 8 or 16 outputs .....	10
4.2. The encoder .....	11
4.3. The outputs .....	11
4.4. Precautions to be taken at welding operations .....	11
5. Outline of the operator terminal.....	12
5.1. Frontview CamCon .....	12
5.2. The output display.....	12
5.3. The seven-segment display .....	12
5.3.1. Display of position or speed .....	12
5.4. The keyboard .....	12
6. Commissioning.....	13
6.1. Complete deletion .....	13
6.2. Initialization.....	13
6.2.1. User key for the system registers.....	13
6.2.2. The encoder resolution .....	14
6.2.3. The Forwards/Reverse change over.....	14
6.2.4. The zero point correction .....	14
6.2.5. Setting of the programming mode.....	14
6.3. The dead time compensation.....	14
6.4. Cam programming in the programming mode "0" .....	15
6.4.1. Selecting an output.....	15
6.4.2. Searching for cams .....	15
6.4.3. Setting the preset value.....	15
6.4.4. Shifting the activation point .....	15
6.4.5. Shifting the deactivation point .....	15
6.4.6. Leaving cam programming .....	16
6.4.7. Examples for cam programming in the programming mode "0" .....	16
6.4.7.1. Programming the first cam.....	16
6.4.7.2. Programming additional cams on an output .....	17
6.4.7.3. Deletion of a particular cam .....	18
6.5. Cam programming in the programming mode "1" .....	19
6.5.1. Selecting an output.....	19
6.5.2. Shifting the activation point .....	19
6.5.3. Shifting the deactivation point .....	19
6.5.4. Leaving cam programming .....	19
6.5.5. Examples for cam programming in the programming mode "1" .....	20
6.5.5.1. Cam programming .....	20
6.5.5.2. Deletion of cams .....	20
7. Outline of operations .....	21
7.1. Switching the standard display.....	21
7.2. Programming of the system constants.....	21
7.3. Dead time programming .....	21
7.4. Cam programming .....	21
8. watch doc .....	22
9. Troubleshooting .....	22
10. Technical data of the CamCon.....	23



## 1. Introduction

Electrical cam switch units have been used successfully by the industry for a long time. The experiences which have been collected in close co-operation during these years have been considered during the development of the CamCon. The result is a compact digital cam switch unit which owns a maximum of user friendliness and reliability.

The following characteristics distinguish the CamCon:

- \* Experienced and reliable hardware
- \* Short circuit-proof outputs
- \* Graphical liquid crystal display with 128x64 picture elements on CamCon DC50/51
- \* As many cams per output as programmable
- \* Optimizing of the switching points while the machine operates
- \* In steps of 100µs adjustable compensation of the mechanical delay time of switch units
- \* Voltage supply 24V DC +/- 20%
- \* Carrier rail assembly according to EN 50022 on CamCon DC16 and DC90.
- \* Switchboard norm encasement 144 x 144 x 63mm according to DIN 43700 on CamCons DC40,50 and 51.
- \* S5 operation group for Simatic® S5 115U, 135U and 155U on CamCon DC115.
- \* S5 connection via PG interface with L1 - BUS.
- \* S7 operation group for Simatic® S7 300 on CamCon DC300.
- \* PLC logic module (optional)
- \* Analog outputs (optional)

**Note:** Simatic® is a registered trademark of the Siemens company.

Cam switch units are being used everywhere where switching procedures are being periodically repeated. Digital cam switch units replace mechanical ones optimally and furthermore offer other advantages, for example:

- \* Simplification of assembly and adjustment procedures
- \* Reproducible adjustments
- \* Standardisation for all possible ranges of operation
- \* Reliability
- \* High switching speed
- \* Delay time compensation

## 2. Principle of function

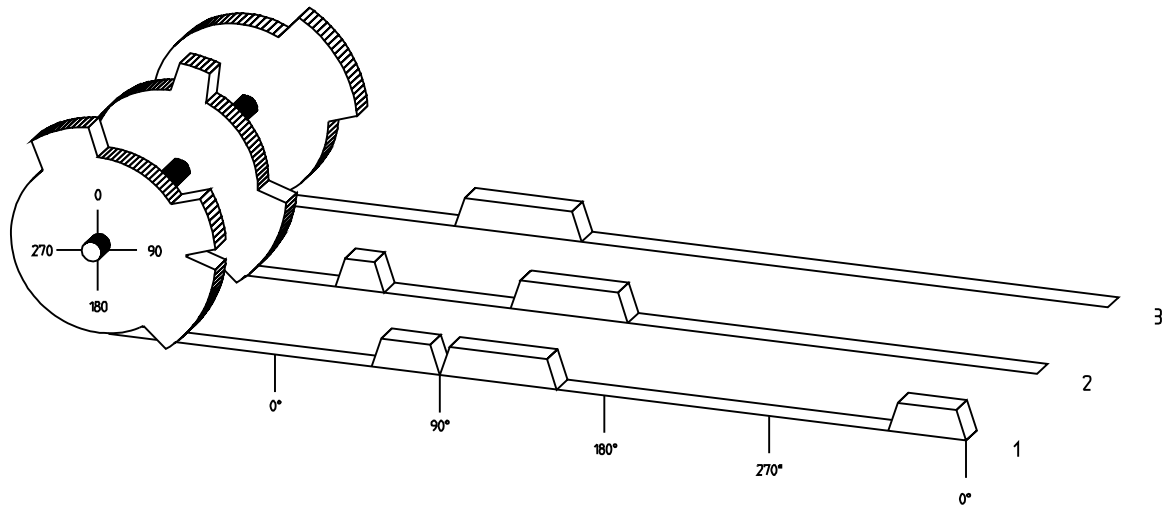

Fig.: Presentation of the principle of a cam switch unit

For a better understanding of the function of a cam switch unit, its principle is presented here. It has 3 outputs containing the following cams:

Output 1:	Cam 1:	Activation point	60°	Deactivation point	85°
	Cam 2:	Activation point	95°	Deactivation point	145°
	Cam 3:	Activation point	325°	Deactivation point	355°
Output 2:	Cam 1:	Activation point	5°	Deactivation point	20°
	Cam 2:	Activation point	95°	Deactivation point	145°
Output 3:	Cam 1:	Activation point	30°	Deactivation point	85°

The 3 as beds presented progressions of the output signals occur, if the 3 cam plates turn anticlockwise past a sensor, which scans the cams on the 0° axis.

The duration of the activation of a mechanical cam switch unit, i.e. the range between the on and off position, is determined by the length of the cams. The length and the position of the cams can only be limitedly varied, which additionally demands a relatively high mechanical and chronological expenditure. With the CamCon, these adjustments are realisable in a fraction of a second, besides the number of the cams per bed is optional. A measuring system, which has been connected to the device reports the position to the CamCon. The CamCon compares this with the programmed on and off positions from all the outputs. If a position appears in a range of a programmed on / off position (cams), all affected outputs will be switched.

## 2.1. Delay time compensation

Every mechanical switching part (e.g. relays, magnetic valves) possesses a delay time, i.e. between the triggering signal and the actual switching of the contacts passes a certain amount of time. Because of that, problems can arise during procedures in which positionings are carried out in a moved system. If such a process is driven with different speeds, different positionings will arise. One would have to generate new (de)activation points for the switching signals for every speed in order to overcome this.

To explain the problem of the delay time compensation, the context shall be clarified using the example of a packaging machine. During the process which is presented by the drawing, a dot of glue is to be applied onto a precisely defined spot of a past going paper web.

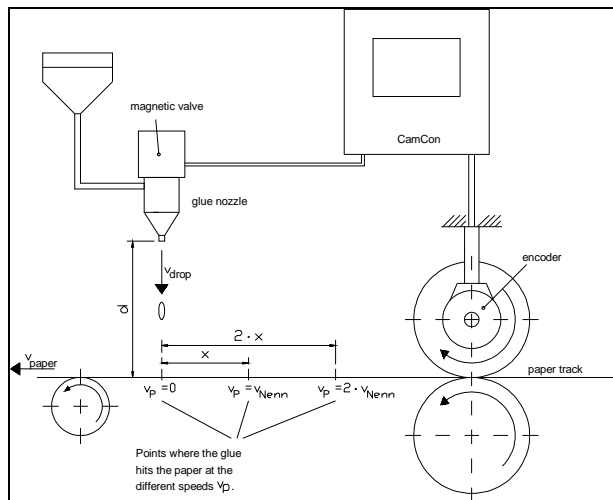

The system has the following parameters:

- $v_p$  - Speed of the paper web
- $v_T$  - Falling speed of the drop of glue
- $d$  - Distance between the glue nozzle and the paper web
- $T_{MV}$  - Delay time of the magnetic valve

This happens without delay time compensation:

As soon as the measuring system reaches a certain position, the CamCon sends out an impulse to the magnetic valve. This opens the glue nozzle for a short time, out of which the drop of glue then shoots. Between the placing of the impulse and the falling of the drop passes a certain time, which is mainly based on the delay time of the magnetic valve  $T_{MV}$ . Another delay results in the time in which the drop needs to cover the distance  $d$  between the glue nozzle and the surface of the paper.

This flight time can be calculated with:

$$t_{\text{Flight}} = \frac{d}{v_T}$$

So a delay time of  $t_{\text{Flight}} + T_{MV}$  results altogether. During this time, the paper web moves a certain distance further on. One could now decrease the position at which the magnetic valve is activated, so that the drop of glue hits the same spot as during standstill. One gains a delay time compensation in this way, which however can only function at one single speed of the paper. As soon as the speed of the system and the paper web is e.g. doubled, the landing range of the drop of glue is moved again by the distance  $x$ , so that it would, without delay time compensation, move to the rear by twice the distance ( $2 \cdot x$ ) altogether.

The automatic delay time compensation of the CamCon makes it now possible to operate with processes with variable speeds. The CamCon gathers the speeds of the system continually and adjusts the cams, which define the moments of switching, on line in dependence of the speed. According to this, the outputs of the switching parts are being switched on or off earlier. The direction of movement is of no importance.

A small numerical example shall serve the illustration:

Assuming that the drive roll with the measuring system has a circumference of 360mm, so that one millimeter at the circumference corresponds exactly to one angle degree of the measuring system. The unit has the following parameter:

$$\begin{aligned}v_{\text{drop}} &= 20\text{m/s} \\d &= 20\text{cm} \\T_{\text{MV}} &= 20\text{ms}\end{aligned}$$

Out of this results a flight time of the drop to

$$t_{\text{Flight}} = \frac{d}{v_T} = \frac{0,2\text{m}}{20\text{m/s}} = 10\text{ms}$$

So the complete delay time amounts to  $T_{\text{dead, altogether}} = T_{\text{MV}} + t_{\text{Flight}} = 20\text{ms} + 10\text{ms} = 30\text{ms}$

During this time the paper web travels by the distance  $x = v_{\text{paper}} \cdot T_{\text{dead, altogether}} = 1\text{m/s} \cdot 30\text{ms} = 30\text{mm}$  further on.

The switching point of the magnetic valve has to be transferred  $30^\circ$  to the front to compensate this delay time.

If one doubles the speed of the system and with that  $v_{\text{paper}}$ , the distance  $x$ , by which the paper web is moving on, is also doubled. In this case the switching point has to be transferred by  $60^\circ$ .

**Tip:** Note that in this explanation the delay time is a solid quantity, which is determined by the mechanical regulation and switching parts as well as by the measurement of the construction, hence it does not change.

If one were now to program the complete delay time of 30ms on the appropriate output of the CamCon, the drop of glue would always hit the exact spot at any speed.



### 2.1.1. Calculating the delay time

There are several possibilities for calculating the delay time of a relay or a valve.

#### 2.1.1.1. Calculating the delay time through relocations that have already occurred

Program the switching point of the relay or valve during a standstill of the machine. We use the switching point of 200 degrees in our example. If the machine is now run with a speed of e.g. 40 min<sup>-1</sup>, a relocation occurs because of the delay time. This relocation is measured and is 40 degrees in our example.

**Attention:** To calculate the relocation correctly you have to set the programmed delay time of the cam switch unit to zero.

The delay time of the switching member is calculated according to the following formula:

$$\text{Delay time ( in sec. )} = \frac{\Delta \text{ way (in degrees)} * 60 \text{ (sec./min.)}}{\text{speed (in min}^{-1}\text{)} * 360 \text{ (degrees/rotations)}}$$

$$\text{Delay time ( in sec. )} = \frac{40 * 60}{40 * 360} = 0.1667 \text{ sec.}$$

The calculated delay time is now set in the CamCon.

#### 2.1.1.2. Calculating the delay time through the difference of measured values

The switching point is determined at a speed of e.g. 50 min<sup>-1</sup>. In our example, the programmed switching point is at 200 degrees. The second measurement occurs at a speed of 80 min<sup>-1</sup>. The needed switching point has to be set to 160 degrees to reach the exact switch point again at 80 min<sup>-1</sup>.

**Attention:** To determine the two switching points you have to set the programmed delay time of the cam switch unit to zero.

The delay time of the switching member is calculated with the following formula:

$$\text{Delay time ( in sec. )} = \frac{\Delta \text{ way (in degrees)} * 60 \text{ (sec./min.)}}{\Delta \text{ speed (in min}^{-1}\text{)} * 360 \text{ (degrees/rotations)}}$$

$$\text{Delay time ( in sec. )} = \frac{40 * 60}{30 * 360} = 0.222 \text{ sec.}$$

The determined delay time is now entered into the cam mechanism. Since this delay time is set for the whole range of the speed, it now becomes necessary to adjust the cam to the speed at 0 min<sup>-1</sup>. To determine the exact activation point you have to enter the difference to the speed 0 min<sup>-1</sup> at the first measured activation point. The difference is calculated according to the following formula:

$$\Delta \text{ way (in degrees)} = \frac{\text{dead time ( in sec. )} * \Delta \text{ time (in min}^{-1}\text{)} * 360 \text{ (degrees/rotations)}}{60 \text{ (sec./min.)}}$$

$$\Delta \text{ way (in degrees)} = \frac{0.222 * 50 * 360}{60} = 66.6 \text{ degrees}$$

The activation point of the cam is now relocated by 67 degrees, from 200 degrees to 267 degrees.

### 3. Installation

The unit is inserted into a cutout for front plate installation (see chapter "3.1. Dimensions" on page 10). Connect the grounding pins on the back of the encasement as well as the cable cover to a grounding point of the switchboard door in the shortest possible way. All cable connections must be done in a cold state! The connection cables, e.g. for the measuring system or the serial interface, must be wired with covers, and the covers have to be grounded on both ends. Analog signals must also be wired with covers, and the covers have to be grounded on one end.

#### 3.1. Dimensions

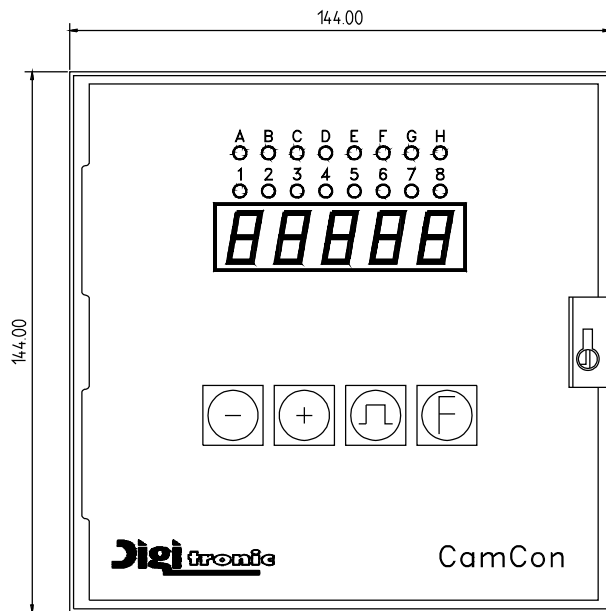

cutout as per DIN 138 +1 x 138 +1

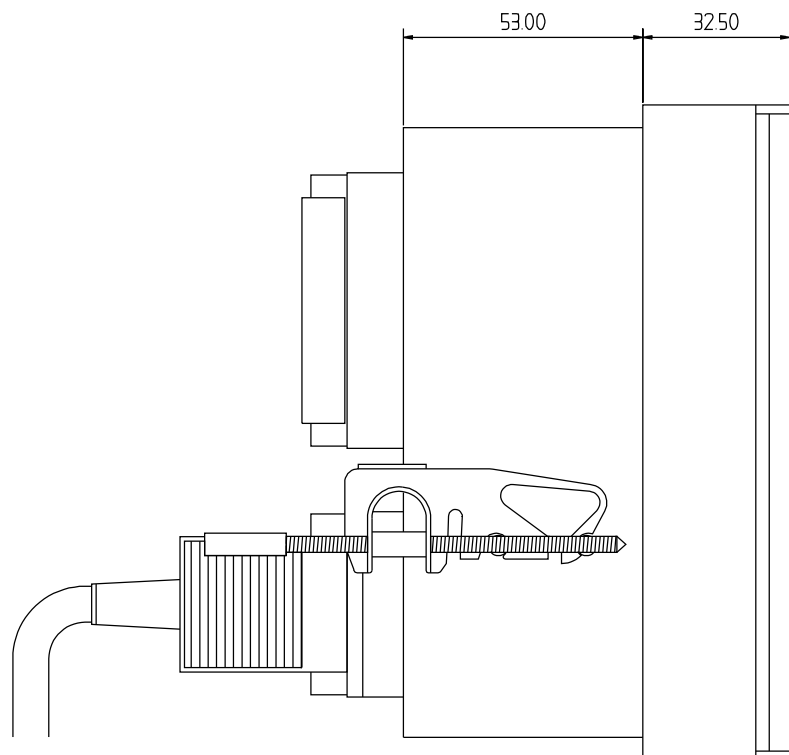
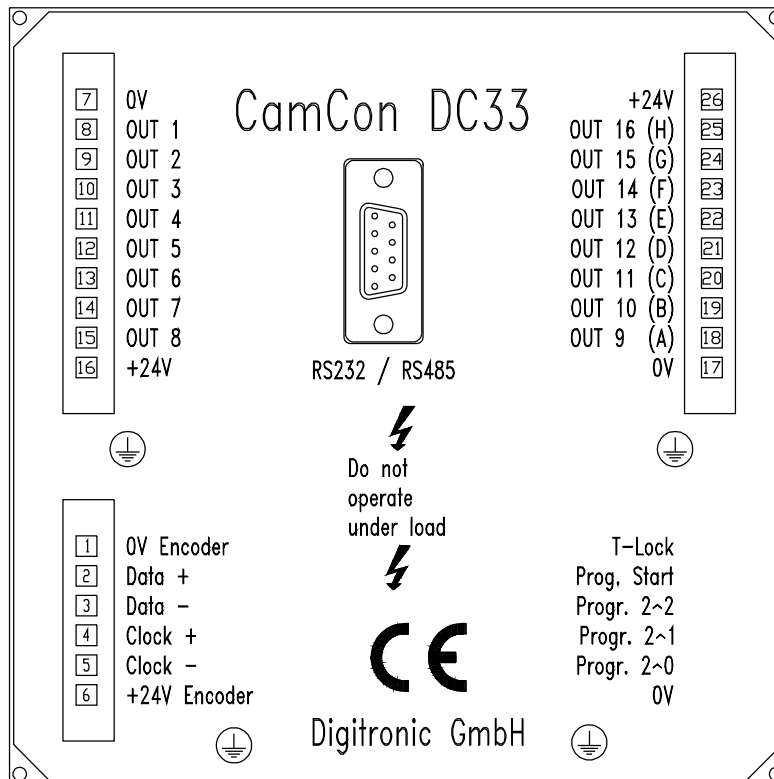

Fig.: Drawing to aid the installation of CamCon

#### 4. Electrical connections



#### 4.1. Pin allocation CamCon with 8 or 16 outputs

Pin 1: 0V for encoder  
 Pin 2: Data A or +  
 Pin 3: Data B or -  
 Pin 4: Clock A or +  
 Pin 5: Clock B or -  
 Pin 6: +24V DC for encoder

Pin 7: 0V supply  
 Pin 8: Output 1  
 Pin 9: Output 2  
 Pin 10: Output 3  
 Pin 11: Output 4  
 Pin 12: Output 5  
 Pin 13: Output 6  
 Pin 14: Output 7  
 Pin 15: Output 8  
 Pin 16: +24V DC supply

#### only for the CamCon with 16 outputs:

Pin 17: 0V supply  
 Pin 18: Output 9 (A)  
 Pin 19: Output 10 (B)  
 Pin 20: Output 11 (C)  
 Pin 21: Output 12 (D)  
 Pin 22: Output 13 (E)  
 Pin 23: Output 14 (F)  
 Pin 24: Output 15 (G)  
 Pin 25: Output 16 (H)  
 Pin 26: +24V DC supply

#### 4.2. The encoder

The encoder is used for getting the actual position, necessary for the cam controller. Only encoders with an SSI interface can be connected to CamCon DC33. The SSI interface is a common interface for absolute single and multiturn encoders. The CamCon supplies the measuring system with 24Volt via this interface. To read the data, CamCon sends a clock signal with an RS422 level to the encoder. The encoder answers synchronously with the output (data) of the position in Gray code. The frequency of the clock signal depends on the length of the cable connecting encoder and CamCon. The cable length can be maximum of 200 metre.

**Note:** The data protocol corresponds with the Stegmann SSI Norm.

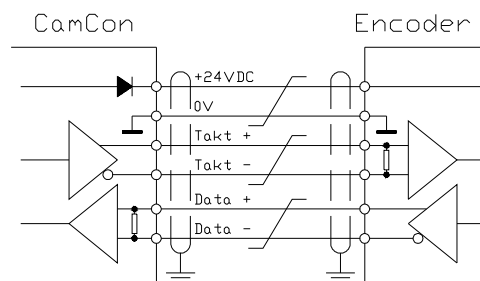
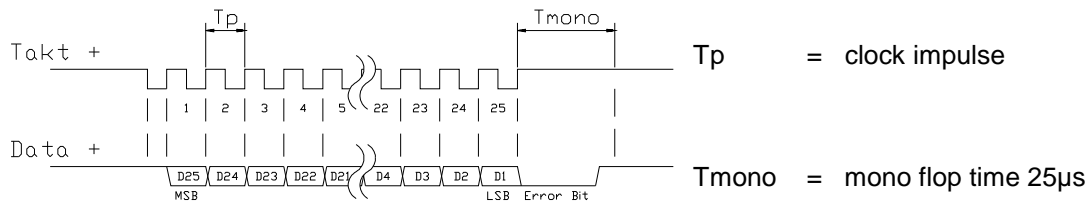

#### Attention:

Use only a covered double entwined connection cable. The wiring should not be near power current lines. Ground the covers at both sides.

#### 4.3. The outputs

CamCon is equipped with either 8 or 16 short circuit-proof outputs, depending on the version. They emit 24V high active signals and are not potentially free. They supply up to 500mA permanent current in a surrounding temperature of 25°C. If an output short circuits or overloads, the device switches off with the "A-Err" message.



**Attention:** *With inductive loads the outputs have to be switched with free wheeling diodes.*

#### 4.4. Precautions to be taken at welding operations

For the duration of welding operations carried out at the machine, the connecting wires concerning the data exchange from the measuring system to the CamCon and the power supply as well as the grounding connections and inputs and outputs have to be separated from the CamCon.

## 5. Outline of the operator terminal

### 5.1. Frontview CamCon

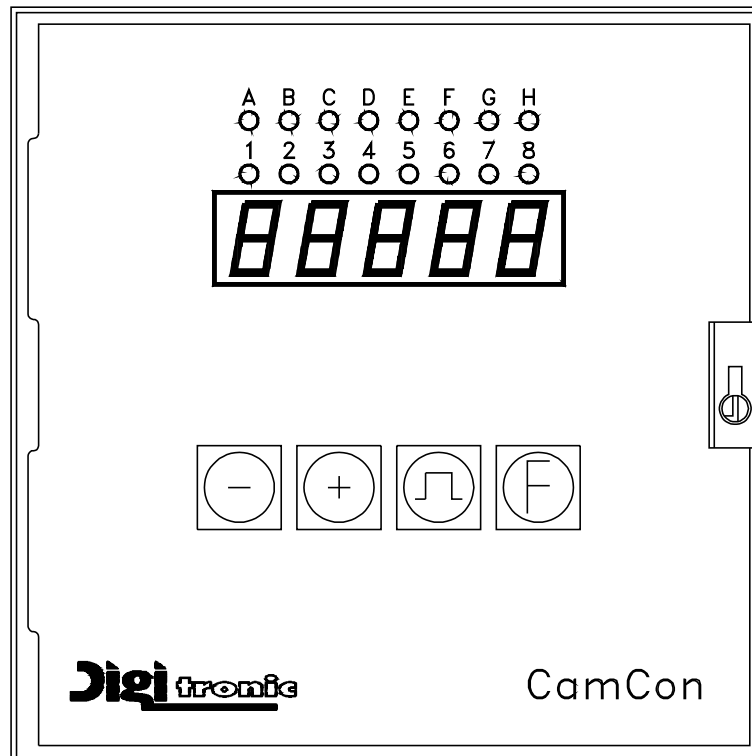

### 5.2. The output display

The output display shows the current states of the outputs. If a LED is illuminated, the corresponding output is active.

### 5.3. The seven-segment display

This display is divided into two ranges. The 1. and the 2. segment show the current mode of CamCon, and the segments 3, 4 and 5 display the value pertaining to this mode.

#### 5.3.1. Display of position or speed

After the activation and after having left the programming modes the 7-segment display shows the rotatory speed in rotations/minute. By pressing the **+** key, the angular position of the encoder, e.g.  $\square \quad | \quad \square \quad \square$  is displayed. If the **-** key is pressed, the display will show the rotatory speed.

### 5.4. The keyboard

The **+** key serves for increasing the input values by the value one. If you keep the **+** key pressed for about two seconds, the input values will increase automatically until released.

The **-** key is used to reduce the input values by the value one. Keeping the **-** key pressed for about two seconds will cause the input values to decrease automatically until the release of the **-** key.

The **□** key serves for the initiation of the programming mode and/or for the modification of the input type.

The **F** key is used for the initiation of the system mode, for the selection of the system constants and/or for selecting the outputs in the programming mode.

## 6. Commissioning

Before activating the device for the first time, please check its wiring (see chapter 4. Electrical connections).



**Attention:** *With induced loads the outputs have to be switched with a freewheeling diode. Covers or inductivities very close to the device inside the switchboard have to be switched with a deletion unit as do those that are wired to or influence the wiring of the device.*

### 6.1. Complete deletion

After the first activation of the supply voltage the program memory is not in an initialized mode. This leads to the CamCon's display showing uncomprehensible symbols. That is why you (at the first activation of your CamCon) have to put a complete deletion into process as follows:

1. Activate the device (supply with voltage, +24V DC).
2. Wait until the display shows either a number or  $\square - \square \square \square$ .
3. Press the  $\square -$  key four times.
4. Press the  $\square +$  key four times.
5. Press the  $\square F$  key (about 2sec.), until  $\square \square \square \square$  is displayed.
6. Press the  $\square \square$  key (about 2sec.), until the display goes out.
7. Release the  $\square \square$  key.

After a while (up to 40sec.) the display is reactivated. This completes the complete deletion. All cams are erased, and all system registers have the standard value.

### 6.2. Initialization

After an activation of the voltage supply or a complete deletion the CamCon is in the standard mode. This mode normally displays the rotational speed, the angular position of the encoder, or an error message. The error message continues to be displayed until the system registers have been adjusted to the encoder, provided the wiring is correct.

#### 6.2.1. User key for the system registers

In order to be able to program the system registers, the following key sequence must be maintained:

1. Press the  $\square -$  key four times.
2. Press the  $\square +$  key four times.
3. Keep the  $\square F$  key pressed for about 2 seconds, until the display shows  $\square \square \square \square$ .

### 6.2.2. The encoder resolution

The display  $\square \square \square \square$  shows the resolution of the encoder in steps per rotation. The CamCon operates with a standard encoder with a resolution of 360 steps per rotation. The resolution cannot be adjusted or changed.

### 6.2.3. The Forwards/Reverse change over

After pressing the  $\square$  key the display shows  $\square \square \square \square$ . The display  $\square \square \square \square$  shows that the encoder is counting upwards clockwise, when looking at the shaft. You can reverse the rotational direction of the encoder by pressing the  $\square$  or the  $\square$  key.  $\square \square \square \square$  is displayed.

### 6.2.4. The zero point correction

If you press the  $\square$  key, the display shows e.g.:  $\square \square \square \square$ . **123** represents the current angular position of the encoder. After having positioned the drive to mechanical "0", you can also shift the current angular position to "0" by pressing the  $\square$  key or the  $\square$  key, so that the mechanical and the electronic zero point coincide. The display shows  $\square \square$ .

### 6.2.5. Setting of the programming mode

$\square \square \square$  appears on the display after you press the  $\square$  key. Here you can set the mode for cam programming. Pressing either the  $\square$  or the  $\square$  key results in a change over from programming mode 0 to programming mode 1. The programming mode 1 is easier to use than the programming mode 0, but it is not possible (in programming mode 1) to program several cams on one output.



You can return to the standard display with an additional pressing of the  $\square$  key. CamCon should now display the current speed, e.g.:  $\square$ . If not, please refer to the chapter "Troubleshooting".

## 6.3. The dead time compensation



Keeping the  $\square$  key pressed (for about 2 sec.) in the standard display mode lets the display show  $\square \square \square \square$ . Here you can enter the dead time for output 1 in the range of 0ms to 255ms. By pressing the  $\square$  key or the  $\square$  key, you can change this value in steps of 1 ms. By pressing the  $\square$  key shortly, you can proceed to the next output, and so on. The display shows e.g.  $\square \square \square \square$ . This way you can enter time factors for every single output, so that they are (de)activated earlier. You can abort the programming of the dead time compensation at all times by pressing the  $\square$  key.

## 6.4. Cam programming in the programming mode "0"



### 6.4.1. Selecting an output

To initiate cam programming press the  key for about 2 sec., until the display shows e.g. | □ \_ \_ \_ . This indicates that there is no programmed cam on output 1 in the 'Output selection' mode. By pressing the  key or the  key you can now select the output on which you want to program cams.



### 6.4.2. Searching for cams



By pressing the  key you leave the 'Output selection' mode | □ \_ \_ \_ and enter the mode 'Cam search' | □ \_ \_ \_ . In the 'Cam search' mode | □ \_ \_ \_ you can search for the cam activation points by pressing the  key. Every time the  key is pressed, CamCon searches the memory for activation points of the cams on the corresponding output. If no cam has been programmed, | □ \_ \_ \_ is displayed. If a cam has been programmed over the whole perimeter, the display shows | □ \_ \_ \_ .

### 6.4.3. Setting the preset value



You leave the 'Cam search' mode | □ \_ \_ \_ and enter the 'Preset' mode | 1 1 1 □ with the pressing of the  key. By pressing the  or the  key you can now select a value, e.g. 100. This value is the originator from which cams may either be reconstructed or erased by changing the activation and the deactivation points.



### 6.4.4. Shifting the activation point

By pressing the  key you leave the 'Preset' mode | 1 1 1 □ and enter the 'Activation point' mode | 1 1 1 □ . A pressing of the  key or the  key shifts the activation point by one step. This is done according to the following system:

A short single pressing of the  key will erase the activation point at the previously displayed preset value, e.g. 100, and then the preset value is increased by 1, e.g. to 101. A short pressing of the  key will lower the preset value (100 in our example) by 1 and then set a new activation point at e.g. 99.

### 6.4.5. Shifting the deactivation point

Pressing the  key once more leads you from the 'Activation point' mode | 1 1 1 □ into the 'Deactivation point' mode | 1 1 1 □ . CamCon will first search for the deactivation point of the current cam (e.g.: | 1 1 1 □ □ ). By pressing the  or the  key the deactivation point is shifted by one step. This is done according to the following system:

A single short pressing of the  key will set a new switching point at the previously displayed preset value, e.g. 100. Then the preset value is increased by one, e.g. to 101. A short pressing of the  key will lower the preset value, e.g. 100, by 1 and then delete the switching point 99. The new deactivation point is then 99. A further pressing of the  key brings you back to the 'Output selection' mode | □ \_ \_ \_ .



### 6.4.6. Leaving cam programming

No matter in which programming mode you are, you can always leave cam programming by pressing the **F** key. The standard display appears .











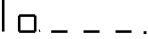

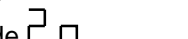

### 6.4.7. Examples for cam programming in the programming mode "0"

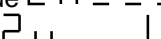
#### 6.4.7.1. Programming the first cam

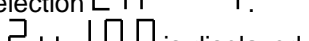
##### Task:

After a complete deletion of the program memory and a successful initialization of the system, a cam shall be programmed for output 2 from 100 to 200.

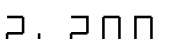

##### Solution:

1. Press the  key (for about 2 sec.), you enter the 'Output selection' mode .
2. Press the  key to select output 2, .
3. Press the  key, you enter the 'Cam search' mode .
4. Press the  key, for the input of the preselection .
5. Press the  key and keep it pressed until  is displayed.
6. If you have released the  key too early or too late, you can adjust the preselection to 100 with the  or the  key.
7. Press the  key, the activation point is displayed.
8. Press the  key to program the deactivation point.
9. Press the  key and keep it pressed until the display shows .

**CAUTION!** Do not keep the key pressed too long. It is best to keep the  key pressed until 190 and then adjust to 200 step by step.

10. Press the **F** key. You return to the standard display.

##### NOTE:











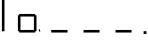

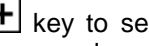

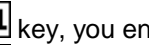
When programming the activation and the deactivation points you are programming "on line", i.e. if you keep the  key pressed for too long, the cam will be programmed too long. Although you can correct this subsequently with the  key, the range between the desired end of the cam and cams entered in excess is erased. All cams already programmed in this range are lost.

### 6.4.7.2. Programming additional cams on an output

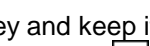
**Task:**

A cam shall be programmed on output 2 from 300 to 330 in addition to an already existing cam, e.g. from 100 to 200.

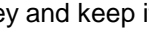

**Solution:**

1. Press the  key (for about 2 sec.), you enter the 'Output selection' mode .
2. Press the  key to select output 2, . The display also shows the begin of the already programmed cam.
3. Press the  key, you enter the 'Cam search' mode .
4. Press the  key for the input of the preselection .
5. Press the  key and keep it pressed until  appears on the display.
6. If you have released the  key too early or too late, you can adjust the preselection to 300 with the  or the  key.
7. Press the  key, the activation point is displayed.
8. Press the  key to program the deactivation point.
9. Press the  key and keep it pressed until  is displayed.

**CAUTION!** Do not keep the key pressed too long. It is best to keep the  key pressed until 320 and then adjust to 330 step by step.

10. Press the  key. You return to the standard display.

**NOTE:**







When programming the activation and the deactivation points you are programming "on line", i.e. if you keep the  key pressed for too long, the cam will be programmed too long. Although you can correct this subsequently with the  key, the range between the desired end of the cam and cams entered in excess is erased. All cams already programmed in this range are lost.

### 6.4.7.3. Deletion of a particular cam

**Task:**

The cam from 300 to 330 on output 2 shall be deleted.

**Solution:**

1. Press the  key (for about 2 sec.), you enter the 'Output selection' mode | □ \_ \_ \_ .
2. Press the  key to select output 2, 2 □ 1 0 0 . The start of the first cam found is displayed.
3. Press the  key, you enter the 'Cam search' mode 2 □ 1 0 0 .
4. Press the  key, the device searches for the start of the next cam. 2 □ 3 0 0 is displayed.
5. Press the  key. The preselection 2 | 3 0 0 is displayed.
6. Press the  key to program the activation point. The display shows 2 r 3 0 0 .
7. Press the  key and keep it pressed until the display shows 2 r 3 3 0 .

**CAUTION!** Do not keep the key pressed too long. It is best to keep the  key pressed until 320 and then adjust to 330 step by step.



8. Press the  key. You return to the standard display.

**NOTE:**



By shifting the cam activation point to the cam deactivation point the programmed cam is deleted. By shifting the activation point beyond the deactivation point deletes the range after the cam (e.g. from 330 to 350). All cams programmed in this range are deleted. A new cam will be placed between 330 and 350 when you move the activation point back to the desired position of 330 !



## 6.5. Cam programming in the programming mode "1"

### 6.5.1. Selecting an output



The cam programming is initiated as follows: Press the  key for about 2 sec., until the display shows e.g. | □ \_ \_ \_ . This indicates that no cam has been programmed on output 1 in the 'Output selection' mode. By pressing the  key or the  key you can now select the output on which you want to program cams.



### 6.5.2. Shifting the activation point

By pressing the  key you leave the 'Output selection' mode | □ \_ \_ \_ and enter the 'Activation point' mode | ▮ \_ \_ \_ . A pressing of the  key or the  key shifts the activation point by one step. This is done according to the following system:



A short single pressing of the  key will erase the activation point at the previously displayed preset value, e.g. 100, and then the preset value is increased by 1, e.g. to 101. A short pressing of the  key will lower the preset value (100 in our example) by 1 and then set a new activation point at e.g. 99.

### 6.5.3. Shifting the deactivation point

Pressing the  key once more leads you from the 'Activation point' mode | ▮ \_ \_ \_ into the 'Deactivation point' mode | ⊥ □ □ □ . CamCon will first search for the deactivation point of the current cam (e.g.: | ⊥ | □ □ ). By pressing the  or the  key the deactivation point is shifted by one step. This is done according to the following system:

A single short pressing of the  key will set a new switching point at the previously displayed preset value, e.g. 100. Then the preset value is increased by one, e.g. to 101. A short pressing of the  key will lower the preset value, e.g. 100, by 1 and then delete the switching point 99. The new deactivation point is then 99. A further pressing of the  key brings you back to the 'Output selection' mode | □ \_ \_ \_ .

### 6.5.4. Leaving cam programming

No matter in which programming mode you are, you can always leave cam programming by pressing the  key. The standard display appears 













## 6.5.5. Examples for cam programming in the programming mode "1"

### 6.5.5.1. Cam programming

#### Task:

After a complete deletion of the program memory and a successful initialization of the system, a cam shall be programmed on output 2 from 100 to 200.

#### Solution:









1. Press the  key (for about 2 sec.), you enter the 'Output selection' mode | 0 \_ \_ \_ .
2. Press the  key to select output 2, 2 0 \_ \_ .
3. Press the  key for the programming of the activation point 2 1 \_ \_ .
4. Press the  key and keep it pressed until 2 1 1 0 0 is displayed.
5. If you released the  key too early or too late, you can adjust the preselection to 100 with the  or the  key.
6. Press the  key to program the deactivation point.
7. Press the  key and keep it pressed until the display shows 2 1 2 0 0 .
8. If you have released the  key too early or too late, you can adjust the deactivation point to 200 with the  or the  key.
9. Press the  key. You return to the standard display.

### 6.5.5.2. Deletion of cams

#### Task:

You want to delete the cam 100 to 200 on output 2.

#### Solution:

1. Press the  key (for about 2 sec.), you enter the 'Output selection' mode | 0 \_ \_ \_ .
2. Press the  key to select output 2, 2 0 1 0 0 . The start of the found cam is displayed.
3. Press the  key to program the activation point. The display shows 2 1 1 0 0 .
4. Press the  key and keep it pressed until 2 1 2 0 0 is displayed.
5. If you released the  key too early, shift the deactivation point to 200 by repeatedly pressing the  key. If you released the  key too late, do not correct it ! The cam is then already erased. Shifting the activation point backwards programs a new cam in consequence. This cam should be deleted.
6. Press the  key. You return to the standard display.

## 7. Outline of operations

### 7.1. Switching the standard display

Press the <b>+</b> key shortly	P 2 3 3	Speed display (min <sup>-1</sup> )
Press the <b>-</b> key shortly	3 3	Position display
	3 3	Speed display (min <sup>-1</sup> )

### 7.2. Programming of the system constants

Press the <b>-</b> key shortly	3 3	Speed display (min <sup>-1</sup> )
Press the <b>-</b> key shortly	3 3	User key for system constants
Press the <b>-</b> key shortly	3 3	User key for system constants
Press the <b>-</b> key shortly	3 3	User key for system constants
Press the <b>-</b> key shortly	3 3	User key for system constants
Press the <b>+</b> key shortly	P 2 3 3	User key for system constants
Press the <b>+</b> key shortly	P 2 3 3	User key for system constants
Press the <b>+</b> key shortly	P 2 3 3	User key for system constants
Press the <b>+</b> key shortly	P 2 3 3	User key for system constants
Press the <b>F</b> key about 2 sec.	G 3 6 0	Encoder resolution
Press the <b>F</b> key shortly	r 1 2 3	Encoder F/R switching
Press the <b>F</b> key shortly	0 1 2 3	Zero point correction
Press the <b>F</b> key shortly	P r 0	Cam programming mode
Press the <b>F</b> key shortly	3 3	Speed display (min <sup>-1</sup> )

You return to the standard display.

### 7.3. Dead time programming

Press the <b>F</b> key about 2 sec.	3 3	Speed display (min <sup>-1</sup> )
Press the <b>F</b> key shortly	t 1 0	Dead time compensation for Output 1
...	t 2 0	Go to Output 2
Press the <b>□</b> key shortly	3 3	Speed display (min <sup>-1</sup> )

You return to the standard display.

### 7.4. Cam programming

Press the <b>□</b> key (about 2 sec.)	0 1 0 0	Speed display (min <sup>-1</sup> )
Press the <b>□</b> key shortly	1 0 1 0 0	Selecting an output
Press the <b>□</b> key shortly	1 1 1 0 0	Searching for cam activation point (only in mode "0")
Press the <b>□</b> key shortly	1 r 1 0 0	Enter position of preselection (only in mode "0")
Press the <b>□</b> key shortly	1 L 1 2 0	Shifting the activation point
Press the <b>□</b> key shortly	1 0 1 0 0	Searching for and shifting the deactivation point
Press the <b>+</b> key shortly	2 0 3 0 0	Selecting an output
Press the <b>F</b> key shortly	3 3	Selecting the next output

Speed display (min<sup>-1</sup>)  
You return to the standard display.

## 8. watch doc

The CamCon deactivates all output within 1ms when an error occurs. This behavior can be used as an extreme error message. Program a cam over the whole range of a chosen output (0 to 360 degrees) (security cam). This output should be slaved into the emergency deactivation circuit. To be able to program a security cam over the whole range.

After the security cam has been programmed, the display shows e.g.:   .

## 9. Troubleshooting





### Problem:

The display remains dark after activation.

### Solution:

The wiring is probably not correct. Check the wiring.





### Problem:

The display shows:  -   .

### Solution:

Either the encoder is connected incorrectly or not at all, or the encoder resolution of the connected encoder does not coincide with the input encoder resolution. Check the wiring to the encoder or the input of the encoder resolution. When the error is corrected, press any key to clear the error message of the display.

### Problem:

The display shows:  -   .

### Solution:

Your outputs are overloaded or have short circuited. Check the wiring and the connected power as well as any inductive loads, that are operated without a free wheel or a deletion unit. An output can supply up to 500mA of current. When the error is corrected, press any key to clear the error message of the display.



**Caution:** *Infavourable cable routing can lead to the deactivation of the outputs, since it builds up a potential that is redirected into the outputs at the closing of a contact. With induced loads the outputs have to be switched with a freewheeling diode. Covers or inductivities very close to the device inside the switchboard have to be switched with a deletion unit as do those that are wired to or influence the wiring of the device.*

## 10. Technical data of the CamCon

Multifunctional display for programming.....	7-segment, 5-digits, 13mm
Number of outputs.....	8 or 16
State display of the outputs.....	a red LED each
Number of programable cams.....	500
Number of programs.....	1
Cycle time, (switching speed).....	1ms
Dead time compensation (DTC).....	for each output
Range of the DTC.....	0 to 255ms
Exactness of the DTC.....	+0 to -1 step
Encoder input.....	synchronous serial (SSI), gray coded
Encoder type.....	AAG60007
Encoder resolution.....	360 steps / rotation
Zero point correction.....	electronical adjustment inside CamCon
Rotatory direction of the encoder.....	is programmed by CamCon
Length of the connecting cable between encoder and CamCon.....	200m
Data security/memory.....	EEPROM
Supply voltage.....	24V DC $\pm$ 20%
Encoder supply voltage.....	with 24V DC over supply voltage of CamCon
Current reception.....	200mA without encoder and outputs
Output current.....	500mA, short circuit proof permanent current (see 4.3. The outputs)
Output voltage.....	24V DC, pluse switching

### Connections for:

Encoder.....	through plug block clips
Voltage supply.....	through plug block clips
Cam outputs.....	through plug block clips
Operating temperature.....	0°C to +55°C

### Cover type for:

Front plate / full sight gate.....	IP 67 / IP 55
Cabinet.....	IP 40
Dimensions.....	see fig. on page 10
Front plate part.....	138 x 138mm + 1
Cabinet (switch plate cabinet by DIN 43700).....	144 x 144 x 63mm (WxHxD)
Cover of the front plate.....	Full sight gate, can be locked with security key
PC - connection.....	with PC30 Software package
Weight.....	about 600g



## 11. Key word table

Activation point, Shifting.....	15; 19
Cable covers .....	9
Cam programming .....	15; 19; 21
Cam programming, Examples .....	16; 20
Commissioning.....	13
Connections, Electrical.....	10
Deactivation point, Shifting.....	15; 19
Dead time compensation .....	14
Dead time programming .....	21
Delay time compensation, Effects.....	6
Delay time, Calculation.....	8
Deletion, Complete.....	13
Dimensions .....	9
Display of position or speed .....	12
Encoder .....	11
Encoder resolution .....	14
F/R change over.....	14
Grounding pins.....	9
Initialization.....	13
Installation .....	9
Installation procedures .....	9
Keyboard .....	12
Leaving cam programming .....	16
millenium .....	2
Operation, Outline .....	21
Operator terminal, Outline.....	12
Output display .....	12
Output, Selection.....	15; 19
Outputs.....	11
Pin allocation.....	10
Precautions .....	11
Preset value, Setting.....	15
Programming mode, Setting .....	14
Searching for cams .....	15
Standard display, Switching .....	21
System constants, Programming .....	21
Table of contents.....	3
Technical data.....	23
Troubleshooting .....	22
User key .....	13
watch doc .....	22
Y2K.....	2
Zero point correction .....	14